

49							
50							
51							
52							
53							
54							
55							
56							
57							

48							
47							
46							
45							
44	ON-OFF Switch	双刀开关	1		250V 10A		
43	Power cord	电源线	1		H05VV-F 3*1mm ²		
42	Power cord holder	压线码	1		PP		
41	Screw	螺丝	2		PT3*4.8		
40	Driver Shaft group	传动轴组	1		ø8 SUS303		
39	Bowl Assembly Base	托座组	1		PAGE+30%GF		
38	waterproof silicone loop	防水硅胶	1		硅胶		
37	Screw	螺丝	1		KT3*10		
36	Usb Cover	USB盖板	1		ABS		
35	USB-PCB	USB板	1				
34	Supporting plate	支撑板	1		AL		
33	Screw	组合螺丝	6		PM4*20带弹垫		
32	rubber plug	胶塞	2		silicon		
31	Belt	同步带	1		HTD3587-3M-70mm		
30	External clip spring	外卡簧	1		ø7.4*7.8 65mm		
29	Big Belt Gear	大带轮	1		PM		
28	Driver	传动头组件	1		PAGE+30%GF		
27	Screw	螺丝	1		KM3*8		
26	Screw Cover	螺丝盖板	1		PAGE+30%GF		
25	Rubber Foot	脚垫	4		silicon		
24	Bottom Cover	底盖	1		ABS		
23	Weight PCB	称重电路板	1				
22	Washer	垫片	1		Φ15*Φ6.2*11mm 电木		
21	Weight Sensor	电子称重传感器	3		55*12.7 10kg		
20	Switch PCB	开关板	1		220-240V 50/60Hz		
19	Screw	螺丝	9		PT3*8		
18	Lampshade	灯罩	1		PP		
17	Knob	按钮	1		ABS		
16	Weight Board	称重板	1		AL		
15	Screw	组合螺丝	3		PM5*13带弹垫		
14	Screw	螺丝	21		PT3.5*12		
13	Screw	组合螺丝	4		PM5*8		
12	Motor Holder	固定板	1		TL 5mm		
11	Cushion	电机减震垫	6		硅胶		
10	Screw	组合螺丝	6		PM4*6带介子		
9	Motor	电机组件	1		220-240V 50-60Hz 1000W		
8	Screw	机牙螺丝	2		M4*6		
7	wind Tube	风罩	1		PP		
6	ornament	装饰圈	1		ABS		
5	Screw	自攻螺丝	14		PT3*6		
4	Power PCB	电路板	1		220-240V 50/60Hz		
3	Top Cover	上盖	1		ABS		
2	Switch PCB	显示屏组件	1		220-240V 50/60Hz 7寸屏		
1	Bowl Assembly	搅拌碗组件	1		SUS304 4.5L 220-240V 1000W		
ITEM	English Name	NAME	QTY		MAT'L & SPEC		PART NO:

				PART NAME: Unit		MATERIAL:	
BADGE NO. OF ZONE				MODIFIED DESCRIPTION		REMARK	
COUNTERSIGN				DATE		DATE	
DESIGNED				DATE		DATE	
DRAWN				DATE		DATE	
CHECKED				DATE		DATE	
APPROVED				DATE		DATE	
				MODEL: CF-2002		PART NO.: CF2002-00-25	
				PRODUCT NAME: Thermo Cooker		WEIGHT SCALE	
				Cofar		东莞市昌久电器科技有限公司	
				Dongguan Cofar Electrical Appliances Tech Co., Ltd			

A4

1

2

3

4

A

B

C

D

E

F

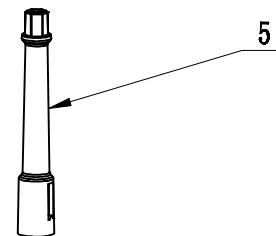
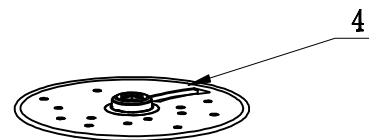
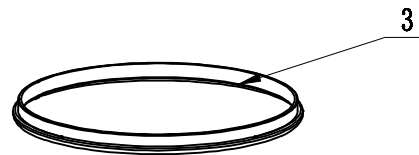
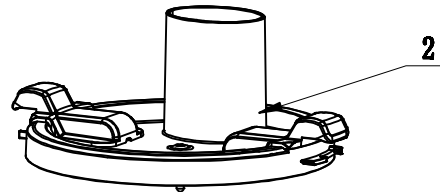
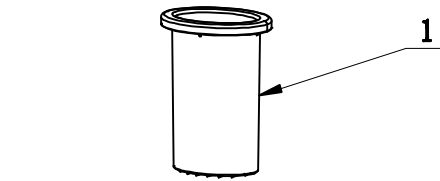
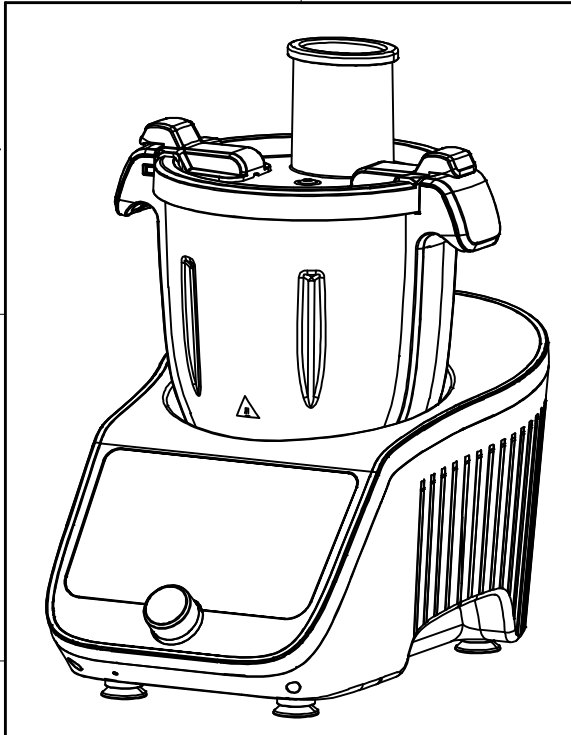

8					
7					
6					
5	Driver shaft	转轴	1	PA66+30%GF	
4	Cutter Disc	切粗丝/厚片刀盘组件	1	SUS430+SUS420	
3	Ring of FP Lid	料理盖密封圈	1	Silicon	
2	FP lid	料理盖(含灰色定位套)	1	AS	
1	Pusher	推杆	1	AS	
ITEM	English Name	NAME	QTY	MAT'L & SPEC	PART NO:

				PART NAME: Food Processor		MATERIAL:	
ECN No.	BADGE	MODIFIED DESCRIPTION	REMARK	MODEL: CF-2002		PART NO. : CF2002-00-24	
COUNTERSIGN				PRODUCT NAME: Thermo Cooker		UNIT mm	WEIGHT 0.48kg
DESIGNED		DATE		 东莞市昌久电器科技有限公司 Dongguan Cofar Electrical Appliances Tech Co., Ltd			
DRAWN		DATE					
CHECKED		DATE					
APPROVED		DATE					

1

2

3

4

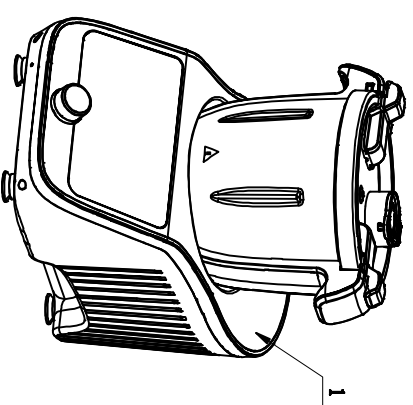
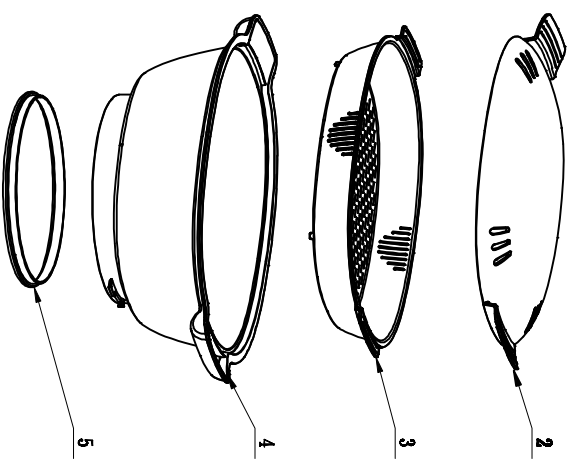
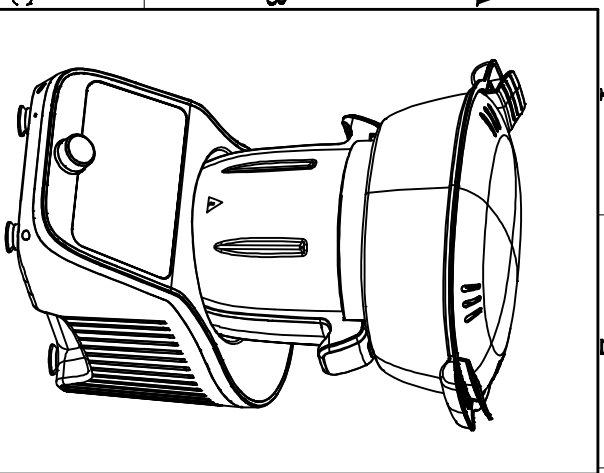

ITEM	English Name	QTY	Material	Part No.
1	2002 多功料理機	1	CR2002 Heater:1000W, motor:1000W	
2	蒸籠蓋	1	PC/PC	
3	蒸籠板	1	PP	
4	蒸籠體	1	PP	
5	蒸籠圈	1	Silicon	

PART NAME: Steamer		MATERIAL:	
BLADE NO. OF ZONE	MODIFIED DESCRIPTION	REMARK	MODEL:
COMPRESSOR			CR-2002
DESIGNED	DATE		PRODUCT NAME: Thermo Cooker
DRAWN	DATE		
CHECKED	DATE		
APPROVED	DATE		

东莞市昌久电器科技有限公司
 Dongguan Cofar Electrical Appliances Tech Co., Ltd.

A 1 2 3 4 5 6 7 8
 B
 C
 D
 E
 F
 1 2 3 4 5 6 7 8

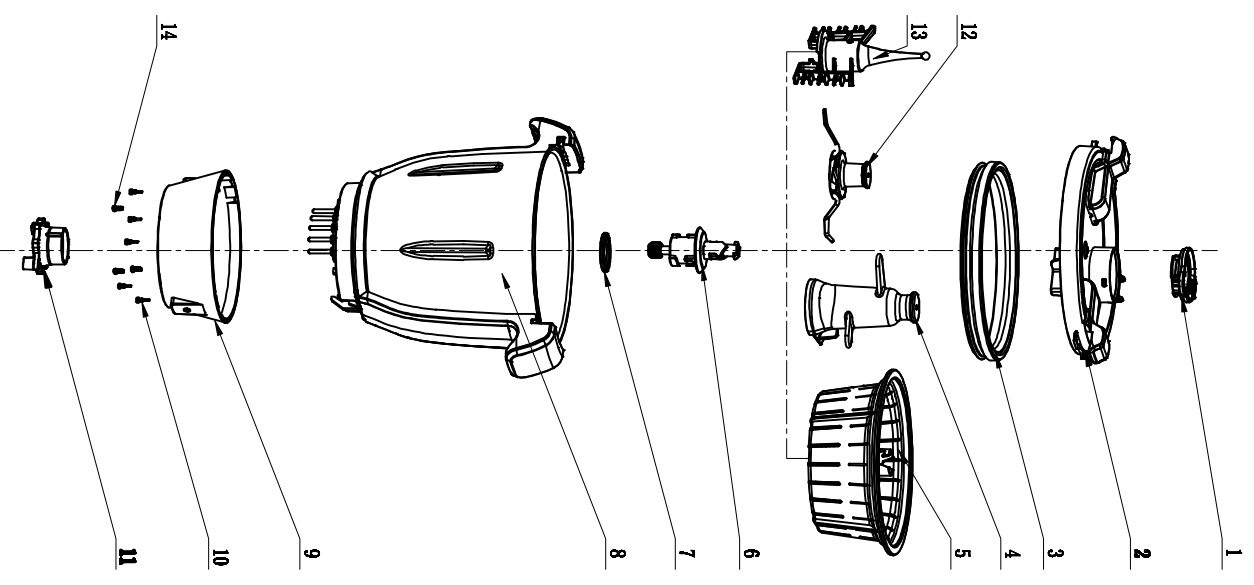
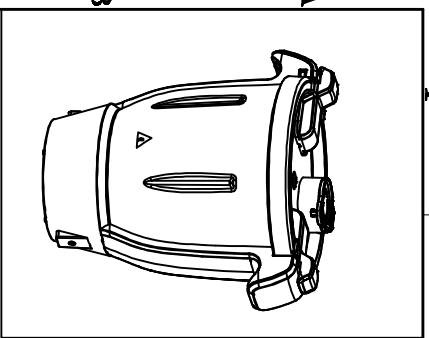

NO.	ITEM NO.	DESCRIPTION	REMARK	UNIT	QTY	MATERIAL	PART NO.
1	Filler Cap	密封盖			1	PC/PC	
2	Blind Lid	锅盖			1	PC/PC	
3	Ring of blind Lid	锅盖密封圈			1	PC/PC	
4	Stirring Paddle	搅拌刀			1	PA66+30%GF	
5	Steam Basket	蒸格			1	PP	
6	blade base assembly	刀座组件			1	CF2002	
7	Ring of Blade Base	刀座密封圈			1	CF2002	
8	Bowl	碗组件			1	SISS304 4.5L 220-240V 1000W	
9	Bowl Base	碗底座			1	ABS	
10	small cushion	减震垫			5	硅胶	
11	blade base Fix	刀座固定套			1	PA66+30%GF	
12	Blade	四叶刀组件			1	PA66+30%GF 刀片SIS420	
13	Whisk	打蛋棒			1	PA66+30%GF	
14	Screw	螺丝			3	PT3.5#12 十字 SISS304	

PART NAME: Bowl Assembly
MATERIAL:

DESIGNED	DATE	DESIGNED	DATE

PRODUCT NAME: Thermoo Cooker
MODEL: CP2002
PART NO.: CP2002-00-21

DESIGNED	DATE	DESIGNED	DATE

WARRANTY: 1 Year
SCALE:

Cofar
 Dongguan Cofar Electrical Appliances Tool Co., Ltd
 东莞市昌久电器科技有限公司